Si1102 AND Si1120 DESIGNER'S GUIDE

1. Introduction

The Si1102 and Si1120 are low-cost, high-performance, active-optical reflectance-based proximity sensors. Both drive an LED to illuminate a target, then measure the reflectance from the target to determine its proximity.

Both the Si1102 and Si1120 use short-duration strobe pulses to measure reflectance. This keeps the average power consumption in the microwatt range. Both devices cancel background dc ambient before making a reflectance measurement. The reflectance measurement is the difference between the dc ambient and dc ambient plus reflection from the target illuminated by the LED.

The Si1102 is a stand-alone, dual-port proximity sensor driving a single LED. It uses an internal analog wakeup controller that is controlled through an external resistor to set the time interval between measurements. The PRX output is maintained between measurements allowing the Si1102 to behave as a proximity on-off function. The Si1102 is well suited for applications, such as electronic toys, powering transmitters for RF alarm sensors, and saving energy in homes or offices.

Although the best performance is achieved with 850 nm LEDs, the Si1102 can also be used in short-range applications where red visible LEDs are useful, such as hand washers or paper towel dispensers.

The Si1102 sensitivity adjustment sets a fixed proximity threshold, a reflectance level at which it will detect proximity. This absolute level threshold may drift around 20% or more depending on temperature, LED supply voltage, LED aging, and other environmental factors. Consequently, although it is possible to set a threshold that is less than 10% different than the absolute reflection, it may not be consistent. It is, therefore, good system practice to allow for some system programmability, such as using potentiometers.

The Si1120 is designed to operate with a microcontroller. Rather than an on/off output as in the Si1102, the Si1120 encodes the reflectance measurement as a pulse-width-modulated output where the pulse width is directly proportional to the measured reflectance.

Silicon Laboratories offers a wide range of microcontrollers that are well-suited for use with the Si1120. Most Silicon Laboratories microcontrollers offer the PCA (Programmable Counter Array) that can easily be used to measure the pulse width output. With the addition of a microcontroller, higher level functions can be added.

The microcontroller can be used to control multiple LEDs, enabling position determination through triangulation. In addition, unique human interface concepts, such as gestures, can be implemented to enhance the user interface for your product. Such an interface can provide product differentiation, resulting in additional product revenue. The microcontroller can also be used to control multiple sensors and a single LED for applications that are particularly power-sensitive.

The Si1120 can be programmed to drive a 400 mA or 50 mA pulse. When used with a microcontroller, it is possible to dynamically change the LED current drive to either optimize for range or lower overall system power consumption. With the microcontroller, the reflectance measurement frequency can be customized based on the current usage state.

Another feature made possible by a microcontroller is the ability to improve the SNR of the reflectance measurement through pulse averaging. When used with IR filters and lenses, it is possible to use the Si1120 and microcontroller to detect human-sized objects one meter away.

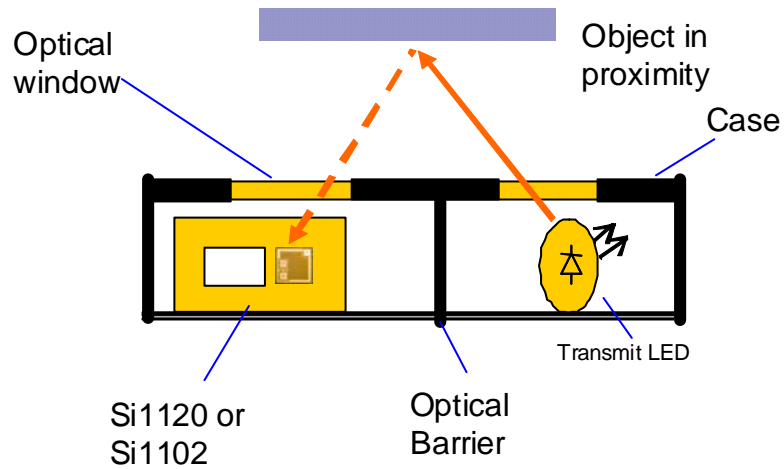

Figure 1. Reflectance-Based Proximity Detection

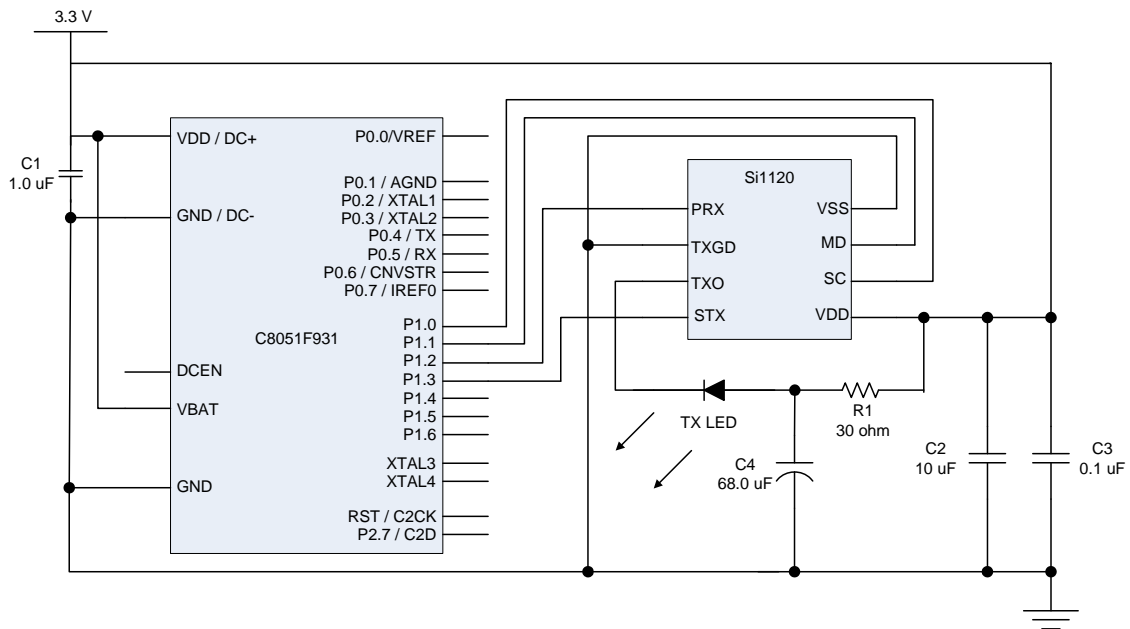

Figure 2. Si1120 Circuit

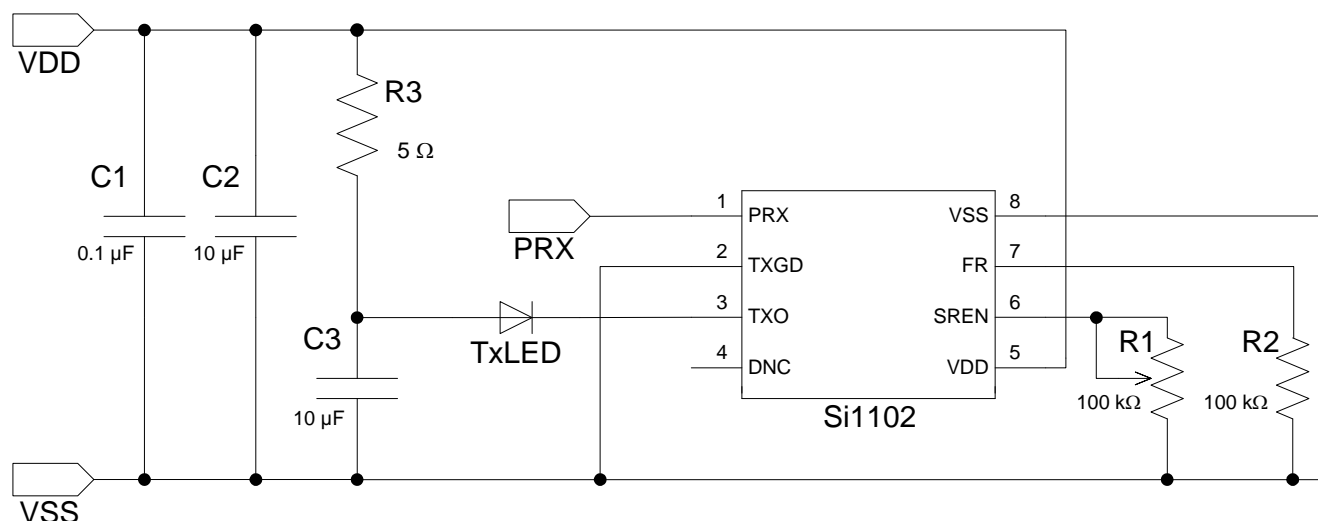

Figure 3. Si1102 Circuit

2. Electrical Considerations

This section is applicable to both the Si1120 and the Si1102. This section focuses on the electrical properties of the Si1120 and Si1102. Items covered include:

- Choosing the right resistor and capacitor for your system
- Choosing the voltage rail used to drive the LED
- Estimating system power requirements
- PCB layout guidelines

The following sections do not need to be read sequentially; it is best to simply reference topics of particular interest.

2.1. TXO (LED Driver) Characteristics

The LED current is governed by the following parameters:

- LED Voltage Rail (V_{LED})
- Resistor (R_{LED})
- Capacitor (C_{LED})

Unlike the Si1102, the Si1120 has a choice of either driving a peak of 50 mA (PRX50 and PRX50H modes) or 400 mA (PRX400 mode). In this section, only the 400 mA drive option is discussed since this peak LED current is common to both the Si1120 and the Si1102. The principles apply regardless of the peak LED current choice.

The current through the LED can come either from the C_{LED} capacitor or from V_{LED} flowing through the resistor, R_{LED} .

Assuming that the C_{LED} is in a “fully charged” initial condition, the LED current initially comes from the charge stored in the capacitor. As the capacitor sources current, the voltage across the capacitor begins to drop. This voltage drop causes a potential difference across R_{LED} . After a sufficient period of time, the current is sourced only through V_{LED} , through the R_{LED} resistor.

A typical Si1102 and Si1120 transistor VI curve is shown in Figure 5. Above one volt, the transistor is in its active region and drives a current of approximately 400 mA. When the TXO voltage is below 0.5 V, the transistor is in its saturation region and no longer sinks the peak 400 mA.

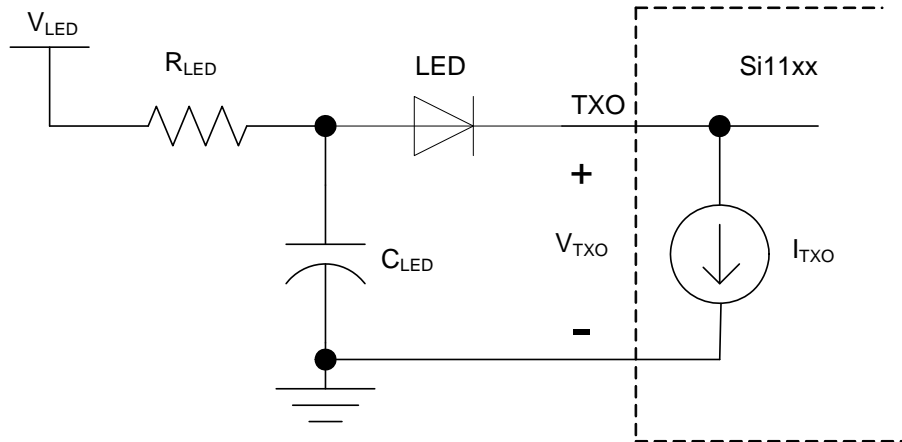

Figure 4. Simplified TXO Circuit

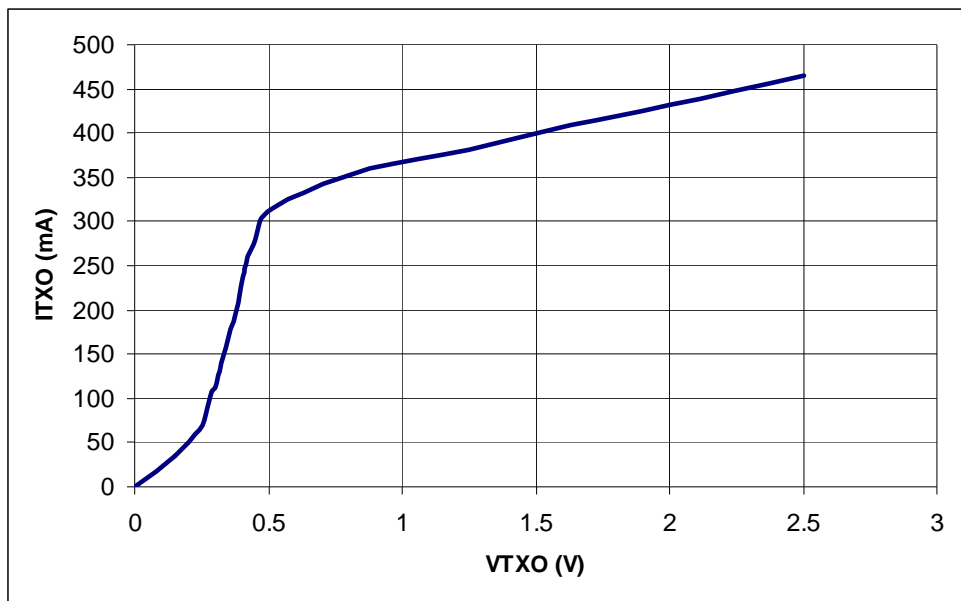

Figure 5. TXO Voltage-Current Characteristic

It is important to touch on the internal operation of the Si1102 and Si1120; it is essential to understanding why the first 20 μ sec of the TXO drive is so critical.

The Si1120 and Si1102 contain an ambient IR circuit designed to reach an equilibrium state in which its current is equal to the photodetector current prior to the start of the LED drive. When the photo detector current increases due to the IR light (indirectly sourced by the LED through reflection), the Ambient IR circuit does not instantaneously adjust its current to match that of the photodetector. Therefore, at that moment, the photodetector current is higher than that of the Ambient IR circuit. This difference in current is the initial detect state.

In the Si1102, this information is fed into an internal circuit. In the Si1120, this event causes the Si1120 to keep the PRX asserted instead of negating. A consequence of this is that the LED continues to emit light and reach the photodiode to keep the photodetector operating at this state with increased current.

The Ambient IR circuit is a servo feedback circuit that then tries to match the current to that of the photodetector current. At the point at which the ambient IR reestablishes equilibrium with the photodetector current, the TXO drive is shut off. Given that the ambient IR circuit takes time to reestablish this equilibrium with the photodiode current, this time frame is proportional to the reflectance.

For the Si1102, the ambient IR circuit correction is nonlinear; correction is faster for high ambients and the longer the correction has taken. For the Si1120, the ambient correction circuit slews at a constant, highly linear rate depending on the gain setting; consequently, the pulse width is a linear function of the reflection.

For the Si1102, the pulse width (proportional to the reflection) is compared with an internal pulse generator (one shot) whose width is controlled by the resistor value on the SREN pin. If the ambient IR circuit matches the increase in ambient from reflection before the SREN circuit times out, then the reflection is below the set threshold. If the SREN pulse generator times out before the IR ambient circuit matches the increase in ambient, then the reflection is above threshold, and PRX goes low. Whichever decision occurs first, either the IR ambient circuit matches the reflection increase or the one shot times out; then, the LED is turned off since there is no reason to leave it on. This behavior can be seen if you put a scope on the TXO pin. TXO pulse width will be constant for out-of-range objects, but, when detection threshold is reached, the pulse width will decrease as the reflection increases.

For the Si1120, the PRX pulse width is kept asserted until the equilibrium state has been reached (as long as STX stays high). The time frame is the basis of the PRX pulse width. Nearby objects reflect more of the LED IR, which results in more photodiode current. More photodiode current means that the internal ambient IR circuit needs more time to overcome the photodiode current. Thus the Si1120 PRX pulse width increases with higher reflectance.

For best linearity, LED current should be consistent throughout the TXO drive. Table 1 summarizes the component selection for best linearity. Although the Si1102 and Si1120 drivers are both constant current above 0.5 V TXO voltage (eliminating the need for a current-limiting resistor), the Si1120 has a high-impedance driver that varies less than 1% per volt on either TXO or VDD (while the Si1102 driver may vary more than 20% per volt). For Si1102 absolute reflection operation, TXO current variation of up to 10% from battery fluctuations is usually not critical. However, for motion detection (where detection of changes in reflection of less than 1% is important), the low variation in TXO current with fluctuations in LED or VDD supplies becomes critical.

Finally, the last consideration in choosing C_{LED} and R_{LED} is the power drawn through TXO. Since the instantaneous power into any node is governed by the voltage-current product, the TXO pin heats up the Si1102 and Si1120 much more if it is drawing 400 mA at a lower, as opposed to higher, TXO voltage. This means that excessively large C_{LED} capacitors or excessively small R_{LED} resistors should be avoided.

Table 1. Recommended R_{LED} and C_{LED} vs. V_{LED}

V_{LED}	R_{LED}	C_{LED}
3.3 V	2 Ω \pm 5%, 1/16 W	10 μ F \pm 20%
5.0 V	5 Ω \pm 5%, 1/4 W	10 μ F \pm 20%
7.0 V	10 Ω \pm 5%, 1/2 W	10 μ F \pm 20%

2.2. Choosing V_{LED}

The LED circuit does not necessarily need to be powered from the same VDD used to power the Si1102 and Si1120. The decision on which voltage rail to use for V_{LED} must be considered. In general, the simplest option is to use an unregulated voltage rail. Using an unregulated voltage rail (must be < 7 V) is generally the best option.

In any system, there are “regulated” and “unregulated” voltage rails. The Si1102 and Si1120 are designed so that the LED can be powered from either.

The fundamental issue governing the choice of V_{LED} voltage rails is the manner in which the instantaneous LED current affects the entire system. It is important that the Si1102 and Si1120 LED circuits do not adversely affect other system components.

2.2.1. LED Current Tapped from Unregulated Voltage Rails

The advantage of using an unregulated power supply is that the effect on other system components is mitigated by the regulator. The regulator is already expected to regulate the voltage to the rest of the system, and any voltage ripple introduced by the sourcing of the LED current does not affect the rest of the system.

2.2.2. LED Current Tapped from Regulated Supply Rails

The first step is to determine whether the regulated rail has enough current for the LED. It is best to consider sourcing 2 ms at 400 mA to best assess the supply capability. It is desirable for the regulator to supply the entire 400 mA.

However, it is no cause for alarm if the regulated supply cannot instantaneously supply the full 400 mA for 2 ms. It is still possible to ascertain feasibility by allowing some of the current to be supplied by capacitors on the voltage rail.

Note that this comes at a price; for capacitors to supply current, voltage must drop. The amount of voltage drop is governed by the following equation:

$$i = C \frac{dv}{dt}$$

Converted to a form we can use for this analysis:

$$dv = dt \times \frac{i}{C}$$

This equation determines the voltage drop that occurs at the point of current draw. The voltage drop is directly proportional to the current drawn from the capacitors and the pulse time and is inversely proportional to the capacitance in the system.

Finally, approximate the amount of current supplied from the capacitors by subtracting the current that can be supplied by the regulator. Thus, the equation reaches its final form:

$$dv = .002 \times \frac{(0.4 - I_{REG})}{C}$$

where:

C is the overall capacitance at the V_{LED} rail

I_{REG} is the current supplied by the regulator for the LED

2.3. Estimating System Power

The system power consumption is dominated by the power delivered to the IR LED. For this reason, the simplest way to estimate system power is to focus on the LED current. The following equation can be used:

$$P_{LED} = (1 - \text{PercentDetect})P_{NO_DETECT} + (\text{PercentDetect}) \times P_{DETECT}$$

$$P_{NO_DETECT} = \text{ConvFreq} \times 15 \mu\text{sec} \times 400 \text{ mA} \times V_{LED}$$

$$P_{DETECT} = \text{ConvFreq} \times 1000 \mu\text{sec} \times 400 \text{ mA} \times V_{LED}$$

For example, assume that the LED current is from a 5 V unregulated supply. Also assume that, for the majority of the time, the Si1102 or Si1120 detects nothing ($P_{DETECT} = 0$). If the conversion frequency is 10 Hz, then:

$$P_{LED} = P_{NO_DETECT} = 10 \text{ Hz} \times 15 \mu\text{sec} \times 400 \text{ mA} \times 5 \text{ V}$$

$$P_{LED} = 300 \mu\text{W}$$

The power drawn by the Si1120 or Si1102 on VDD is small compared to the power used in the LED. For the Si1120, it is recommended that the host firmware keep the Si1120 in its low-power state. Given the same assumptions, the power drawn by the Si1120 when powered at VDD is:

$$P_{CHIP} = \text{ConvFreq} \times 15 \mu\text{sec} \times 14 \text{ mA} \times V_{DD}$$

$$P_{CHIP} = 6.9 \mu\text{W}$$

2.4. PCB Layout Guidelines

Both TXO LED drivers on the Si1102 and Si1120 were designed to have slow rise and fall times of around a few hundred nanoseconds intended to keep di/dt below several mA/ns, minimizing inductive ground bounce, inductive coupling to adjacent signal lines, and EMI effects. Usually, current resistive voltage drops are more of an issue for the 400 mA drivers for currents in the LED and ground return paths including the LED decoupling capacitors. However, when solder is present on a PCB, trace resistances are normally small enough so that, usually, no special layout considerations are warranted. Note that the current flows through two current loops: One loop is formed from the C_{LED} capacitor to its local ground, and the other loop is formed from the V_{LED} to ground.

2.5. Mathematical Model of the LED Circuit

Previous sections discussed the fact that the LED circuit can be sourced from either the C_{LED} or the LED voltage rail, V_{LED} . It is useful to have an equation that provides a way of calculating how long the LED is operating at 400 mA. Such an equation can be derived from the simplified LED circuit of Figure 6, with a constant-current source approximation of the transistor and a simple constant voltage source model of the LED.

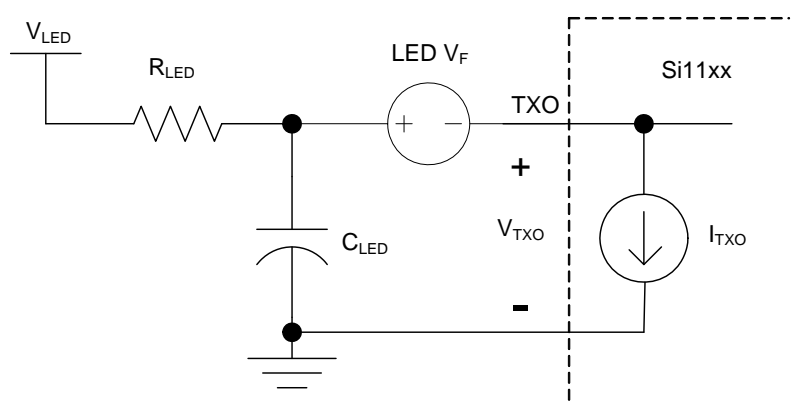

Figure 6. Simplified LED Circuit

Thus, the TXO voltage of the asserting edge is:

$$V_{TXO} = (V_{LED} - V_F) \times e^{\left(\frac{-t}{R_{LED} \times C_{LED}}\right)} + (V_{LED} - V_F - 400 \text{ mA} \times R_{LED})$$

Since the current is a function of voltage, it can implicitly be deduced that the current is being sunk by the TXO node. The transistor characteristics show that the boundary between the transistor active region and the saturation region is somewhere between 0.5 and 1.0 V; so, by assigning $V_{TXO} = 0.7 \text{ V}$ and solving for time, t , the time needed for the transistor to transition from the active region to the saturation region can be calculated:

$$t = R_{LED} \times C_{LED} \times \ln\left(\frac{V_{LED} - V_F - 400 \text{ mA} \times R_{LED} - 0.7}{V_{LED} - V_F}\right)$$

where:

V_{LED} is the voltage rail of the LED

R_{LED} is the resistor

C_{LED} is the capacitor

V_F is the forward voltage of the SFH 4650 LED = 1.7 V @ 400 mA

3. Optical Considerations

This section contains various light-related topics helpful in understanding the light environment and its effect on the Si1102 and Si1120. In general, the following sections are self-contained and need not be read sequentially.

Some of the topics covered are:

- Basic reflectance proximity principles
- Single port vs. dual port windows
- Receiver sensitivity of the Si1102 and Si1120
- Light noise
- Improved range
- LEDs

3.1. Reflectance Proximity Principles

Unlike Passive Infrared Receivers (PIR), which detect object motion by sensing changes in illuminated or naturally-emitted infrared, reflectance proximity devices actively illuminate the object with an emitter, directly measuring reflectance. However, unlike radar or lidar, which measure reflectance transit time to determine distance, reflectance proximity sensors use signal level and optical techniques to determine range. Because the reflectance from an object falls off with the fourth power of the distance (as with radar), if the object's angle is less than the beam width of the emitter or receiver, the signal level of the reflectance can provide a range estimate typically within a factor of two since an object's reflectance does not typically vary by more than about ten to one.

Although, this same fourth-power response severely limits range beyond about ½ meter without optical lensing or averaging, it does mean that large or even very reflective objects more than 2x further than the proximity range will not cause spurious detection, unlike PIR devices.

3.2. Single Port vs. Dual Port

Single-port operation, where the same window is used for both transmit and receive, creates significant receiver overload issues (even for radar). Single port operation is particularly problematic with non-transit time reflectance-based systems since the reflectance from a common shared window for the transmit LED and the receive photodiode produces a very large interfering signal with no way of differentiating the reflection from the window or object (unlike transit time systems). Without some type of optical isolation, a single window will easily have 100x more reflectance from the window than the object being detected, even if it is only a few centimeters away. This is also why a camera flash uses an optical path separate from the imaging path (unlike very short-range microscopes, which use the imaging objective to illuminate the object) and why car headlights are not behind the windshield.

Dual-Port operation will always give the best performance. The Si1102 only operates in dual-port mode requiring very high optical isolation where the leakage coupling from the LED to the IC is always less than the reflectance from an object. However, the Si1120 can be used in either dual-port or single-port mode. In single port mode (PRX50H), the Si1120 requires motion detection signal processing. For long-range proximity sensing (usually over ½ meter), high isolation dual-port operation is normally not possible since there are normally many large objects within proximity range, such as walls, desktops, etc. These nearby objects return a large reflectance relative to any moving object that needs to be detected. However, for best performance, it is desirable to minimize optical coupling between the transmitting LED and detector. Excessive coupling increases noise floor and spurious motion detection due to ambient light modulation.

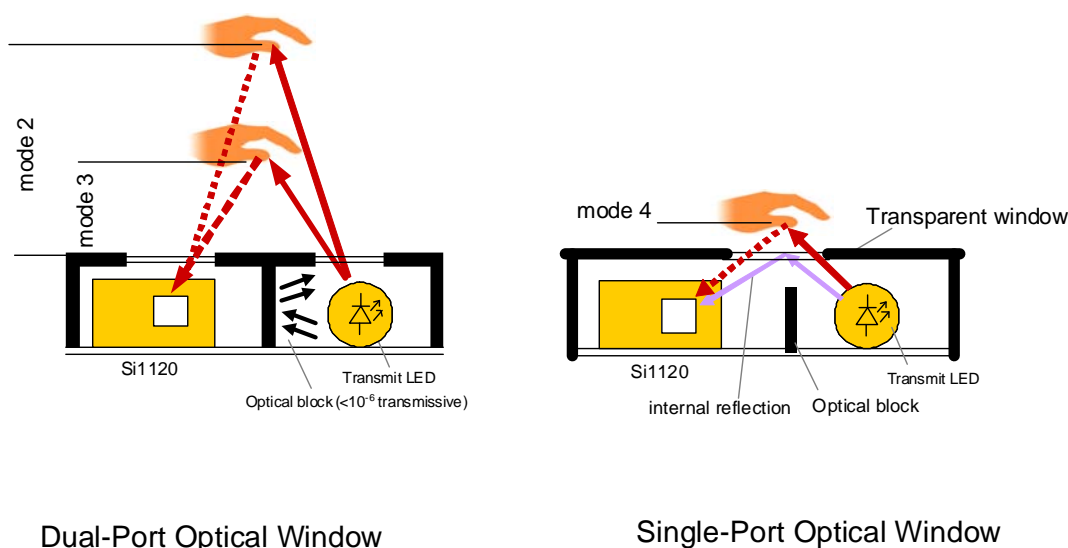

Figure 7. Single Port vs. Dual Port

3.3. Proximity Reflectance Sensitivity

For a short $10\ \mu\text{s}$ pulse, the internal noise floor for both of these products is equivalent to around $0.5\ \mu\text{W}/\text{cm}^2$ RMS ($\sim 1.5\ \mu\text{s}$ PWM in high-sensitivity) of radiance at the peak response. This makes the lowest practical pulse detection threshold around $2\ \mu\text{W}/\text{cm}^2$ (12 dB S/N) in low light noise environments. Lower thresholds can be used with averaging techniques.

An efficient 850 nm infrared LED emitter driven with 400 mA of peak current might output up to 80 mW of infrared. In a lensed LED package, narrowing the beam width to $\pm 15^\circ$ might produce 100 mW/sr, which results in an irradiance of 100 mW/cm² if the receiving (RX) proximity IC is placed 1 cm directly in front of the transmit (TX) LED. Note that the dynamic range of noise floor to maximum signal is about 1 to 200,000 or 106 dB ($20 \times \log 200000 = 106\ \text{dB}$).

Typically, the transmit LED is aimed away from the receiving IC, but, if placed next to the IC with an infrared plastic window only a few millimeters away, the reflected TX levels at the IC may be over $1\ \text{mW}/\text{cm}^2$. Consequently, because it is dual-port only, when using the Si1102, the optical coupling from the LED to the receiver must be below the detect object threshold or below the noise floor. When using an efficient LED and driving with 400 mA, this may be as much as 106 dB or 2×10^5 . Generally, this is only possible with a dual-port optical structure in which the emitting LED is completely isolated and radiates its output through a separate aperture in the product case different from the receiving window or hole. If the TX LED and IC are close to each other, this may require an internal optical fence between the two. However, for shorter-range applications ($\sim 5\text{--}10\ \text{cm}$), a single window with an optical barrier, such as black rubber between TX and receive (the black rubber must be sealed tightly to the interior surface of the window), may provide sufficient optical isolation. At 5–10 cm, the reflectance from a target object will be several hundred times higher. Since the criteria for dual port is that the non-target coupling needs to be less than the target, the stray coupling needs to be less than $\sim 10^3$. Since an LED next to the IC reflecting from a transparent plastic window probably has about 3% reflectance relative to a mirror (especially if the LED is laterally spaced by at least twice the distance to the window), then the optical coupling need only be reduced by another factor of 30. This can generally be achieved by an optical barrier from the PC board to the inside surface of the window. Some light will light-pipe internally, but it is usually low enough to allow 5 to 10 cm response.

However, it is important to keep in mind that, due to this same very high dynamic range, high optical loss ports are acceptable. A 30 dB (31.6 to 1 attenuation) loss only results in one third the range (up to 15 cm). This means existing holes in product cases not designed for optical use may be acceptable for short-range proximity sensing; so, the receiving IC might be put next to a speaker or microphone hole that even has a screen over it, and the emitting infrared LED might be placed behind a glass display screen. In fact, by attenuating the IC input, there is often not much loss in range over what might arise from worst-case environmental light noise. If given two semi-opaque windows, one of which is more opaque than the other, it is best to place the LED under the less opaque location and let the Si1120 or Si1102 be in the more opaque location. This choice will result in a better signal-to-noise ratio.

Users are warned that it is possible to adjust the Si1102 to have high apparent sensitivity where the TX to RX coupling might be as much as 10 to 100 times more than the reflectance from the detected object. This type of adjustment will not be stable since drift in the gain or power supply voltage can cause spurious detects or no detects. The LED has a high temperature coefficient of around 0.4%/C. Consequently, a 10 °C change can cause a 4% decrease in signal.

If it is unavoidable that a high optical coupling exists between the TX (LED) and RX (Si1120), the Si1120 may still be used for motion detection applications, even under this somewhat difficult condition. Essentially, motion detection looks for changes in reflection over the last second or so, ignoring longer-term slower changes. For example, the repetitive pulse width (sampled every 100 ms) output would be averaged over the last 10 seconds, and a motion detection event is determined to occur if the average pulse width value over the last second has changed by at least 10 μ sec. In high-sensitivity proximity mode (PRX50H), 10 μ sec of pulse width corresponds to about 3.3 nW/cm² of reflectance change. The Si1120 offers two proximity ranges that differ in pulse width sensitivity by 9. The less sensitive range overloads (maximum pulse width) at about ten times higher input levels. In a high-reflectance environment, the lower sensitivity range may need to be used.

Although motion detection cannot unambiguously detect the presence or absence of an object unless it moves, it can estimate object distance and possibly direction of motion when the object moves. Because of the fourth-power effect, a 20% change in distance results in a change in measured reflectance of over two to one. Since any motion-detected object must return a reflectance that is more than the change threshold, this means that we should be able to accurately and easily detect object movement. Direction of motion can be valuable but may require multiple LED sources.

If the Si1120 is not used for motion but, rather, as a two-port absolute proximity detector, the calibrate mode (OFC) should be used to maximize performance. This mode is implemented internally in the Si1102, but, in the Si1120, it is provided as a separate mode. The calibration essentially measures the zero reflectance value by making proximity measurement with the LED TX driver turned off.

If a microcontroller controls multiple LEDs, it is possible to perform this calibration function by disabling the LED and doing a proximity measurement (in either high or low sensitivity). The calibration function is important since the zero reflection offset value can change by a small but significant amount depending on the dc ambient. Because the dc ambient may be changing rapidly, it is important to perform a calibrate measurement immediately before the proximity measurement without delay between the two measurements. The jitter on the calibration pulse is a measure of noise in the environment and, consequently, can be used to set a minimum detect value; this might be set to one to several times the peak-to-peak jitter value in order to set a robust detect threshold higher than the environmental noise.

For motion detection, the calibrate function is usually not necessary since the long-term average provides the reference.

On the Si1120, the VIRL Ambient Mode has the same Reflectance-Pulse Width transfer function as the PRX400 or PRX50 Proximity Modes. Therefore, it is possible to use the VIRL Ambient Mode (looking for excessive PRX jitter) as a way of debugging the presence of severe environmental noise when the PRX400 or PRX50 operations result in excessive PRX jitter. In the same way, the VIRH Ambient Mode can be used to debug the PRX50H Proximity Mode.

3.4. Light Noise

The low-cost silicon photodiode used in the proximity sensor has a peak response in the near infrared but also has a significant response in the visible light region unless blocked by a filter. Consequently, both the visible and infrared characteristics of the environment can limit the performance of these proximity sensors. Light in the environment is measured in terms of either Lux, which is illuminance (visual intensity), or in W/m^2 , which is irradiance (power per area).

One of the topics relevant to ambient light and noise issues pertaining to reflectance proximity sensors is the Luminous Efficacy of Radiation (LER). The LER is the ratio of luminous flux to radiant flux. As a reference, direct sunlight at noon provides about 100 mW/cm^2 of irradiance (received power) or 110 klux of illuminance (visual intensity), usually the maximum continuous light level that a proximity sensor will encounter. Indoor lighting levels are typically less than 1 klux or about $230\mu\text{W/cm}^2$ if the light is from efficient lighting (with no infrared like fluorescent), but, if the 1 klux is from incandescent lights, it will produce about 1.5 mW/cm^2 silicon weighted response (relative to the mW/cm^2 for a source at the silicon diode peak response) due to their high infrared output. Sunlight has about one-fourth to one-fifth the silicon diode infrared response per lux as an incandescent bulb.

The silicon photodiodes used in the Si1102 and Si1120 tend to have a broad response from about 350 to 1000 nm, with a peak around 830 nm.

Light noise in the environment arises principally from shot noise, 120 Hz or 100 Hz ac mains light modulation, and high-frequency electronic ballasts used in fluorescent lights (especially compact fluorescents or CFLs). The behavior of the noise sources is different in the visible versus infrared wavelength bands.

Shot noise on a photodiode is proportional to the square root of the current or background ambient level. Generally, the largest shot noise occurs in direct sunlight ($\sim 100\text{ mW/cm}^2$), which, for both devices, is equivalent to an RMS noise of about $3\mu\text{W/cm}^2$. A tenfold reduction to 10 mW/cm^2 (shade) will reduce this noise to about $1\mu\text{W/cm}^2$. Below 2 mW/cm^2 , the shot noise is less than the noise floor. Generally, indoor lighting is less than 1 klux and for it to exceed 1.5 mW/cm^2 requires either daylight, window lighting, or bright incandescent lighting. Bright fluorescent lighting is much less than these levels. Consequently, shot noise has little effect on sensitivity for most indoor applications unless the proximity devices are directly under strong incandescent lighting. Even in direct sunlight, the increase in noise floor only reduces detection range by less than twofold.

The peak-to-peak ripple of incandescent or halogen light sources at 120/100 Hz is about 10% of the average value, but, since incandescent or halogen contains significant power in the infrared region (eight times more infrared than visible light) and since the photodiodes (used for proximity sensing) respond primarily to infrared light, shot noise is a dominant noise source when the proximity detectors are under direct incandescent or halogen light. Fluorescent lights can actually have much higher light ripple percentage than this for both standard ballasts, but virtually the entire ripple is in the visible band. Most high-frequency inverter ballasts filter the input rectified voltage to reduce 120 Hz/100 Hz ripple or visible flicker but may still have peak-to-peak mains ripple comparable to incandescent ballasts. Of course, any other type of lighting powered from the ac mains, whether white LED, industrial sodium lights, mercury vapor, etc., will all typically have these 120/100 Hz components.

In addition, the high-frequency ballasts on fluorescents typically use 20 kHz (long tubes) to 40 kHz (CFLs) inverters, which generate a triangular current waveform that, when folded, causes a 2x frequency light modulation of the ultraviolet light from the mercury vapor plasma discharge. The actual peak-to-peak visible light ripple at 40 kHz or 80 kHz is much less ($<5\%$) than the ultraviolet ripple due to the time constant of the phosphors used on the inside of the tube. Although the mercury plasma mostly generates ultraviolet, it produces a small amount of visible and infrared radiation directly, which can leak past the phosphor. The peak-to-peak percentage modulation of the infrared component can be quite large, although the absolute value is typically low. Without infrared filtering, CFL noise is typically about $5\mu\text{W/cm}^2$ to $10\mu\text{W/cm}^2$ in most CFL illuminated environments. Consequently, for shorter range applications where detect thresholds are above $20\mu\text{W/cm}^2$, infrared filtering is not necessary.

For best performance, it is recommended that infrared filtering be available for the Si1120 if the ALS function is not used. For the Si1102, infrared filtering is necessary. Although infrared filtering of the receiver IC can remove visible light inverter noise, it generally has little effect on shot noise or 120/100 Hz infrared from incandescent lights. However, both the Si1102 and Si1120 electrically filter 120/100 Hz noise to reduce its level by 50 dB, or 316 to 1.

On the Si1120, 120/100 Hz noise can be mitigated for motion sensing by sampling exactly every 50 ms since there are exactly six cycles of 120 Hz or five cycles of 100 Hz. Similarly, to improve sensitivity and reduce the effects of 120/100 Hz, multi-strobe integration periods should be in exact multiples of 50 ms.

3.5. Improving Range

As with radar or lidar, beaming of transmit and receive signals (with dish or directional antennas) is important for improved performance. Similarly, for reflectance proximity sensors, lenses that concentrate and beam the reflected light can improve range and more accurately define proximity spaces.

Using lenses can increase the range to several meters on both devices. The use of a lens on the receiver increases the signal level and reduces noise pickup from undesirable directions, while a lens on the emitting LED narrows the beam and increases its power angle density in the direction in which it is pointed. The crossover region of the transmit and receive optical beams can provide a proximity detection in space. In addition, multiple, separately-strobed LEDs can be used to define both specific proximity region overlaps and relative positions in space, or two LEDs defining different width cones can be used to determine if an object is above or moving directly above a point or off to the side.

The main tradeoff in using lenses is that they tend to make the optical system more “directional”. However, if the goal is to increase the range of detection, it certainly merits consideration.

Besides using lenses to improve sensitivity, pulse averaging can also increase range by 3x or more, but this is only viable on the Si1120. Pulse averaging decreases the effects of both internal noise and external noise, typically improving S/N proportional to the square root of the number of measurement cycles averaged. For example, averaging 10,000 cycles will improve signal-to-noise by a factor of 100, which will typically improve range by a factor of 10.

Multiple strobes on the PWM output of the Si1120, can be integrated to improve signal-to-noise. Normally, the signal-to-noise improvement is proportional to the square root of the total number of strobe cycles integrated. For example, if 40,000 strobe cycles are integrated, the signal-to-noise ratio should improve by about 200, which, in turn, will increase proximity range by about 3.7 giving a range of two meters without lens. Of course, the total power consumption increases proportionally to the number of strobes. For maximum sampling rate, a dual-port structure should be used in order minimize pulse width by minimizing very near local reflection. However, high-sensitivity integration requires motion detection since, in most applications, at two meters range, there are fixed weak reflectors closer than two meters, such as walls, floors, ceilings, and doors).

If a lens is added on the LED that produces a 10 degree beam width from a 60° arc of the LED, that will increase mw/sr by 6^2 or 36. Similarly, since the active infrared silicon photodiode area on the Si1102 or S1120 is about 1 mm², a lens with 7 mm diameter, will increase power density in $\mu\text{W}/\text{cm}^2$ by about 38x on the active photodiode. The fourth power of the products of both the TX and receive gain is about 6, the increase in proximity range. This illustrates that small lenses can improve range much more than multi-strobe integration. Note that LEDs with built-in lenses are available in the market.

Finally, the third basic range-increasing technique is to use safety reflectors or reflective material. These reflectors use the three-surface-corner reflector principle in which light bouncing off the surfaces of the corner of a cube goes directly back to its source. Because the returning light is not diverging, the reflectance falls off much less than the fourth power; typically, only a few square inches of reflective tape will easily double or triple the proximity range. Using all three range extension techniques of reflector tape, lenses, and signal integration, an interrupter motion detector with a range of 30 meters may be possible using the Si1120.

3.6. LED Parameters and Multiple LED Operation

Best performance is generally achieved with the highest output efficiency 850 nm LEDs. However, 940 nm LEDs can also work. Red LEDs have reduced range but may be suitable in applications where it is desirable to have a visible proximity indicator. White LEDs, which convert blue to white, are not recommended because of the long rise and decay time constant of the phosphors used to broaden or whiten the wavelength.

The Si1120 can be used to drive multiple LEDs in conjunction with microcontroller GPIO pins to control multiplexing switches to steer the TXO driver to multiple LEDs. With multiple LEDs, a wide variety of enhanced applications become possible.

For example the proximity sensor may be placed on the front of a motorized toy with an LED on each side to allow the toy to sense whether an obstacle is to its left or right and steer away from it or, conversely, to allow a robot doll head to track an object within proximity range by turning its head to keep both reflections at equal amplitude.

For human interfaces, multiple appropriately located and lensed LEDs can be used to determine hand gestures laterally, vertically, inward, and outward by measuring reflectance and applying suitable algorithms. Simple examples include using hand motion to control the dimming on-off function of a light switch, control picture viewing in an electronic picture frame, or page through documents on e-readers. The proximity sensor can also turn on the picture frame when a viewer's motion is detected nearby and turn it off to save power after the viewer leaves.

3.7. Motion Detection

When used with a microcontroller, the Si1120 can be used to implement a simple motion detection system. The simplest motion detection system requires only a single LED. However, if it is desired to cover a larger area, it may be necessary to have multiple LEDs, each targeting a different direction. The number of LEDs used in such a motion detection system is dependent on the angle coverage. For example, it will take approximately four to five 20° half-angle LEDs to cover 180°.

For motion systems, motion sensitivity is a function of the time between samples. Rapid sampling rates will have less difference between adjacent samples. Typically, for human motion detection, sample periods can be anywhere from 10 ms to 1 second between samples. If higher sampling rates are used to integrate to improve signal-to-noise, moving averages delayed by at least 1 s are usually required. Of course, motion systems can indicate motion towards or away from, which is sometimes useful.

When using motion detection algorithms that detect a very small percentage change in reflection, it is important that the LED driver not saturate but stay in constant current mode in order to minimize the effects of power supply fluctuations on LED TX current, which may cause spurious motion detection. A few percent variation in LED current from pulse to pulse is not critical. These fluctuations can occur if the LED driver is saturated due to a high LED drop or a series current-limiting resistor and the power supply voltage is changing due to other loads or even the LED driver. The 400 mA LED driver is designed to be connected to an independent voltage supply up to 7 V in order to prevent overloading of the regulated Vdd supply. Often, the LED anode supply may have a significant voltage ripple because it is an unregulated battery or input supply with significant wire drop load ripple, etc.

Imagine that we have a simple LED circuit with only a resistor and an LED with a 3 V supply. In this case, there is nominally a 2 V constant voltage drop across the LED with only a 1 V drop across the resistor. When there is a 100 mV change on the 3 V supply, this 100 mV change appears primarily across the resistor because the 2 V drop across the LED is generally constant, due to the nature of diodes. A 100 mV drop, given an initial resistor voltage of 1 V, translates directly to a 10% drop in current. A 10% drop in current implies a 10% change in total reflectance, and this can easily be 10 times more than the motion change threshold.

In order to prevent LED supply modulation, the Si1120 LED TXO driver has been designed to have very high constant current impedance. The 400 mA (or 50 mA) internal current limit has less than a 1% per volt change in current. Consequently, a 100 mV change in LED anode supply will cause less than a 0.1% change in LED intensity, which is much more desirable for sensitive motion detection algorithms.

Another source of spurious motion detection can arise from dc ambient modulation of the receive gain. On the Si1120, the photodiode and analog front end may have a 1% change in gain over the extremes or dc ambient. This might happen if, in direct sunlight, a shadow falls across the IC receiver. Obviously, if the reflectance is already very high, a 1% change may be more than the motion detection threshold. Again, this is a reason to minimize stray optical coupling for motion detection to keep the ambient gain modulation below the minimum detection threshold.

To mitigate such issues, the motion algorithm can increase the minimum detect change threshold proportional to the product of total dc ambient times total reflectance. The effect is that the motion detection range will decrease in a high infrared ambient environment, such as typical outdoor daylight.

3.8. Equation Model of the SFH 4650 LED

The radiant intensity of an LED is a function of the angle relative to surface normal. A mathematical equation of the SFH 4650 LED has been derived empirically to make it easier to calculate the expected radiant intensity at any given angle relative to the surface normal. The equation uses degrees rather than radians for ease of comparison with the SFH 4650 LED data sheet plot.

The radiant intensity of the SFH 4650 as a function of the incident angle can be shown by the following equation:

$$0.25\left(1 - \frac{\theta}{90}\right) + 0.75 \cos^{12}(\theta)$$

where $\theta = 0$ to 90

The mathematical model is shown in Figure 8.

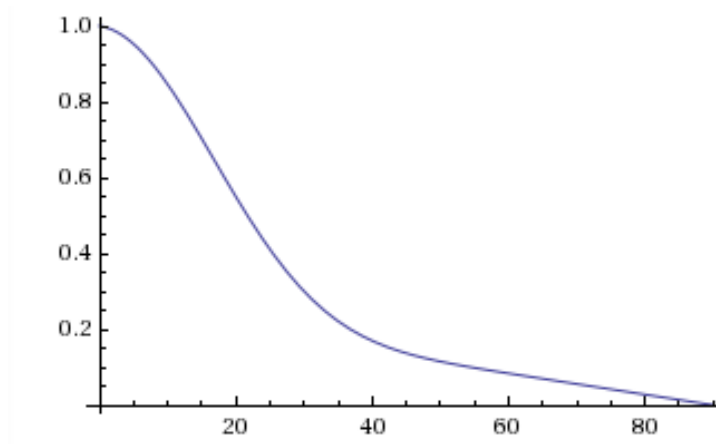

Figure 8. Radiant Intensity vs. Angle for the SFH 4650 Model

3.9. Calculating Irradiance from a Diffuse Surface

This section demonstrates how to trace a light ray from an SFH 4650 LED to a Lambertian diffuse surface, then down to a detector, such as the Si1120 or Si1102. In this simple example, the only source is the SFH 4650 LED.

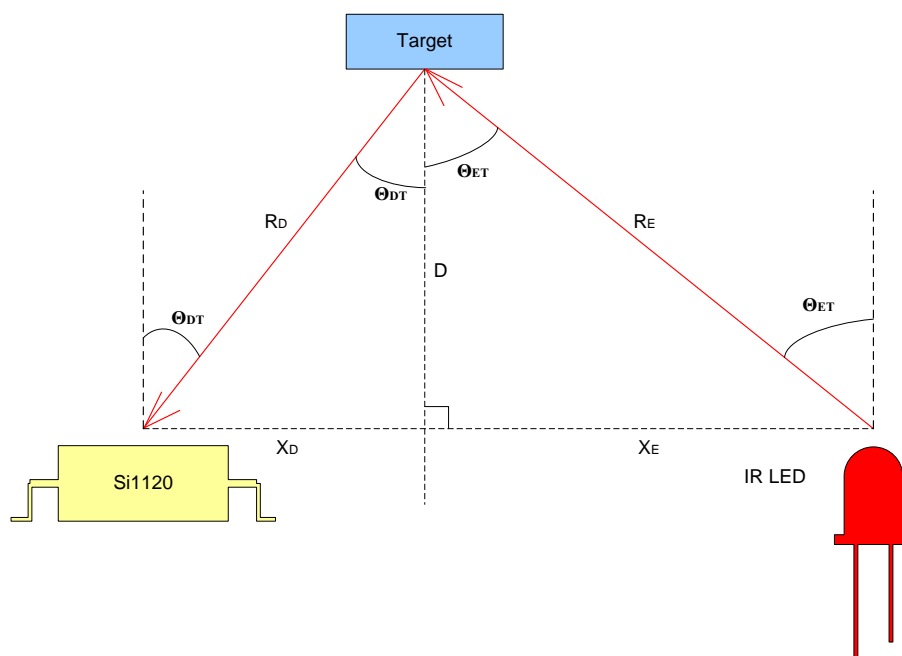

Figure 9. Simple Optical Problem

In this example, we need to first determine which light rays fall on the detector. It is a better approach to trace light rays from the detector backwards to the emitter. The reason for the reverse ray tracing method is that emitter rays failing to reach the detector do not result in any irradiance measured at the detector. Emitter rays that miss the detector are, therefore, insignificant. If we had chosen to begin at the emitter, we may end up analyzing more rays than is necessary. For this example, forward ray tracing or reverse ray tracing yields the same result. However, when it is time to analyze a larger object by breaking the object into multiple flat polygonal surfaces, reverse ray tracing can save computation time.

In this example, we assume that the target (with an area, A) is sufficiently small, such that there exists only a single ray for us to analyze. Assuming that the target has an area of A and that the target is horizontal, the incident angle θ_{DT} is formed. Here, the target is assumed to be a Lambertian diffuse surface.

Since the surface is not a specular surface, it does not abide by the "Law of Reflection" which states that the "angle of incidence equals the angle of reflection". The Law of Reflection applies only to specular objects and does not apply to Lambertian surfaces. A Lambertian surface is an ideal diffuse surface having a constant radiance regardless of the view angle. Most surfaces have Lambertian properties with slight specular highlights near the angle defined by the Law of Reflection. In general, the Lambertian model provides a good first-order approximation of most objects, including dry skin and clothing.

In a Lambertian surface, any rays falling onto it are diffused in all directions. The main property of a Lambertian surface is that the radiance ($W/m^2\text{-sr}$) is isotropic. The other property of Lambertian surfaces is that the radiant intensity from the surface is a function of the cosine of the surface normal. When an observer looks at a Lambertian surface, the "brightness" (analogous to radiance) looks the same from all angles; an example is a matte surface. Looking at the matte surface, there are no specular highlights. The reason the radiance is isotropic (even though the radiant intensity has a cosine function) is that the surface subtends a smaller angle to the observer by the same cosine factor; so, even when one looks at a surface from the side, the area of the surface becomes smaller by the same factor.

AN442

The point is that Θ_{DT} does not have to equal Θ_{ET} , at least not for Lambertian surfaces. What is important is that the target is being illuminated by the LED at an angle of Θ_{ET} . The emitter is an SFH 4650 and is assumed to be a point source. However, it is an unusual point source in that the radiant intensity is a function of Θ_{ET} . For now, we will represent the radiant intensity of the SFH 4650 as:

$$I_E = f(\Theta_{ET})$$

units are in W/sr

The LED irradiates the surface, A. The amount of radiant power at the distance, R_E , is essentially the product of the LED radiant intensity and the solid angle that the target intercepts; therefore, the radiant power captured by the target is:

$$P = I_E \times \frac{(A \cos \Theta_{ET})}{R_E^2}$$

units are in W

The irradiance from the surface is a ratio of the power per unit area; therefore, the surface irradiance is:

$$E_T = I_E \times \frac{\cos \Theta_{ET}}{R_E^2}$$

Given that the surface is assumed to be Lambertian, it can be shown that the radiance is:

$$L_T = E_T \times \frac{R}{\pi}$$

where $R < 1$

This leads to:

$$L_T = \frac{(R \times I_E \times \cos \Theta_{ET})}{(R_E^2 \times \pi)}$$

The Lambertian surface now becomes the light source to the detector.

When possible, one should always try to simplify the calculation if assumptions can be made. It is possible to perform an integration of each point on the Lambertian surface and determine how each point contributes to the irradiance at the detector. However, it is best to invoke the "rule of five".

The "rule of five" helps determine when a light source can be considered a single point. It is commonly stated that a light source represents 0.03 steradians to the observer; so, if the ratio of the largest dimension of the light source to the distance is less than 1/5, the surface can be considered a point source:

$$E_D = \frac{I_T}{R_D^2} \text{ if } \frac{A^{0.5}}{RD} < 5$$

From the perspective of the detector, the radiant intensity of the Lambertian surface is:

$$I_T = L_T A \cos \Theta_{DT}$$

units are in $\frac{W}{sr}$

Therefore:

$$E_D = \frac{(L_T A \cos \Theta_{DT})}{R_D^2} \quad \text{if } \frac{A^{0.5}}{RD} < 5$$

$$\text{units are in } \frac{W}{m^2}$$

and

$$E_D = \frac{(A \times R \times I_E \times \cos \Theta_{ET} \times \cos \Theta_{ED})}{(R_E^2 \times R_D^2 \times \pi)}$$

$$\text{units are in } \frac{W}{m^2}$$

Since the SFH 4650 has a mathematical equation:

$$I_E = I_0 \left(0.25 \times \left(1 - \frac{\Theta_{ET}}{90 \text{ deg}} \right) + 0.75 \times \cos^{12}(\Theta_{ET}) \right)$$

ED from the contribution of that surface can be derived by plugging in the angles, reflectance R of the surface, the area A, and the distances RE and RD.

Note that in Figure 9, the dimension, D, represents the distance of the target to the PCB hosting both the SFH 4650 and the Si1120. As D increases, the Θ_{ET} and Θ_{ED} angles approach 0. Also, the dimensions, R_D and R_E , get closer to the dimension, D. This simplifies E_D :

$$E_D = \frac{(A \times R \times I_0)}{(D^4 \times \pi)}$$

So, it is indeed a fourth root function, as expected for small targets.

The analysis can be repeated for as many segments as necessary to cover the entire illuminated surface. As shown, the irradiance, E_D , was basically the contribution of a small Lambertian surface irradiated by the SFH 4650.

3.10. Calculating Irradiance from a Specular Surface Reflection

When operating in single-port, the window is shared between the detector and the LED. There are actually two reflection coefficients, one for each polarity. The reflection coefficients are a function of the material differences at the junction and the refractive index, n. Air = 1, and, for a transparent polycarbonate material, it is approximately 1.6.

The reflection coefficient is in the neighborhood of 10%, depending on the material. However, whatever R is, the easiest method of calculating the effect of the LED on the detector is to create an image of the specular reflection and then evaluate at twice the distance.

In this example, we assume that the LED and the detector are 2 cm away. Assume that the glass is 1 cm away so that the angles of incidence and reflection are 45°. Using the approximate SFH 4650 mathematical model, the SFH 4650 at 45° has a radiant intensity of 175 mW/sr x 0.137 = 24 mW/sr assuming 400 mA current. The SFH 4650 nominally has a 50 mW/sr at 100 mA, and the derating curve shows that, at 400 mA, there is a 3.5x increase. The equation below is a derived SFH 4650 model that was used to derive this 24 mW/sr result.

$$I_E = I_0 \left(0.25 \times \left(1 - \frac{\Theta}{90 \text{ deg}} \right) + 0.75 \times \cos^{12}(\Theta) \right)$$

It is important to notice that the radiant intensity of the SFH 4650 decreases with increasing Θ . For example, at 60° , the radiant intensity is $0.084 \times 50 \text{ mW/sr} = 14.7 \text{ mW/sr}$, which is around 60% of the radiant intensity at 45° .

Returning to the example, the distance is 2.83 cm to the virtual image. Assuming a coefficient of reflection of 10% and applying the inverse square law to the virtual image, the expected irradiance at the detector is $24 \text{ mW/sr} \times 10\% / (2.83 \text{ cm})^2 = 300 \text{ }\mu\text{W/cm}^2$.

Since an object's reflectance can be as low as $1 \text{ }\mu\text{W/cm}^2$, this internal reflection represents 300 times that of the object being detected, and this analysis has not yet considered the secondary reflections.

It is recommended that optical blocking be used to reduce this internal reflection. If this is not possible, one should consider the geometry and the LED characteristics in calculating how to reduce the internal reflection.

As shown in this example, the incident angle formed at the reflection point is the same angle used in the calculation of the LED radiant intensity. Since the radiant intensity of the LED decreases with increasing incidence angle, we can reduce the amount of unwanted specular reflection by increasing the incident angle.

Increasing the incidence angle can be achieved by increasing the separation between the LED and the detector. The other consequence of moving the detector away from the LED is that the virtual image becomes farther away. Imagine that the separation between the LED and the Si1120 is increased from 2 to 4 cm. This will yield an angle of 63° instead of 45° . This also increases the distance of the virtual image to 3.46 cm. The resulting reflectance is $175 \text{ mW/sr} \times (0.075) \times 10\% / (3.46 \text{ cm})^2 = 109 \text{ }\mu\text{W/cm}^2$. This is nearly a third of the original $300 \text{ }\mu\text{W/cm}^2$ unwanted irradiance.

Geometrically speaking, another way of increasing the incidence angle is by moving the window closer to both the IR LED and the Si1120. For example, if the glass is 0.25 cm from the LED and Si1120 instead of 1 cm, the incidence and reflection angles will no longer be 45° , but will now be $\arctan(1/0.25) = 76^\circ$. The virtual image is now 2.06 cm away. $175 \text{ mW/sr} \times (0.039) \times 10\% / (2.06 \text{ cm})^2 = 160 \text{ }\mu\text{W/cm}^2$. This is nearly half of the original $300 \text{ }\mu\text{W/cm}^2$.

Now, consider what happens if the separation is increased while the glass distance is decreased. The angle will become 83° , and the virtual image becomes 4.03 cm distant. $175 \text{ mW/sr} \times (0.0195) \times 10\% / (4.03 \text{ cm})^2 = 21 \text{ }\mu\text{W/cm}^2$; so, doing both methods decreases the unwanted irradiance by an order of magnitude, relative to the original 300 mW/cm^2 value.

Note that these calculations do not account for secondary reflections and will always be higher. The point being made here is that, in a single-port case, the primary specular reflection can be reduced by increasing the separation between the LED and the Si1120 and by decreasing the distance between the glass and the Si1120 and LED.

Another way of looking at this is by relating to human experience. While in broad daylight, or when one tries to look inside a room through a glass window, it is generally difficult to see anything inside, even though it might be expected that the outside light illuminate the room. The best strategy to see something inside the room is to move closer to the window and apply optical blocking (by using one's hands) to block the sun's rays.

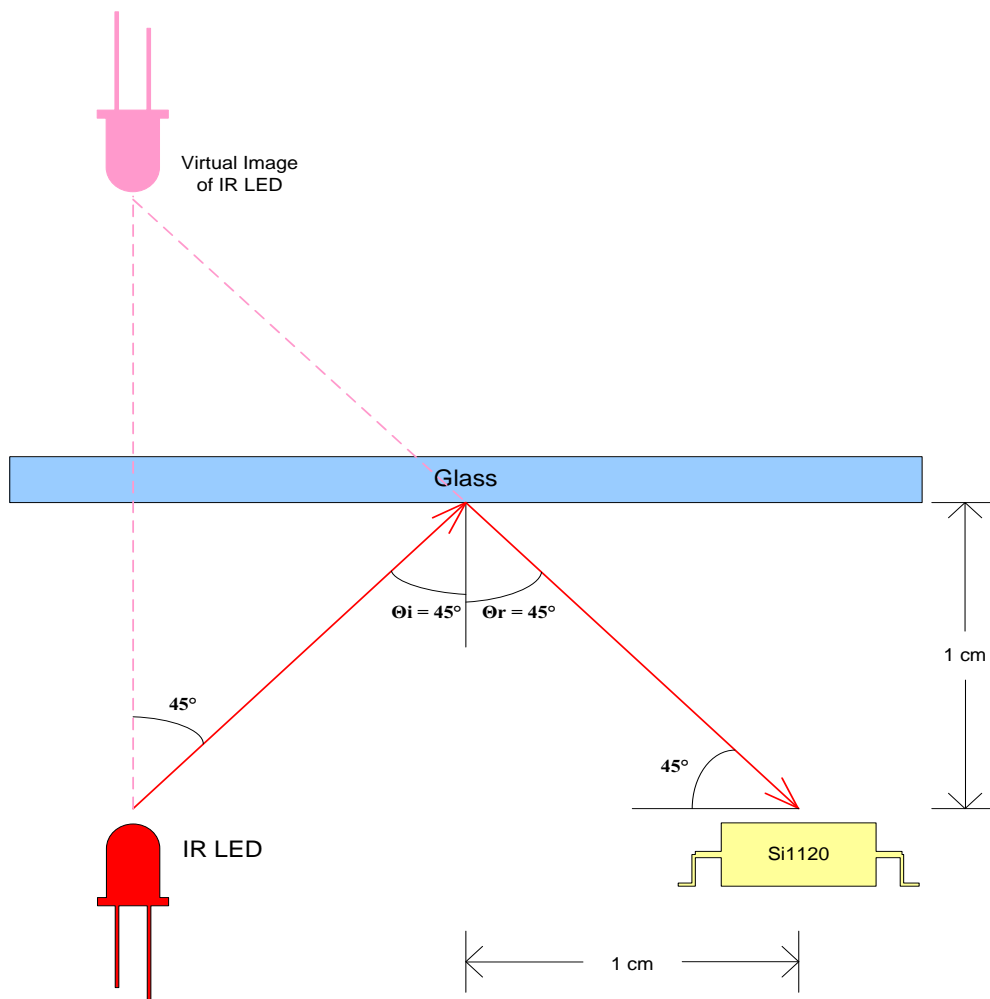

Figure 10. Specular Reflection

3.11. Determining the Reflection Coefficient of a Window

This section provides more details on how to calculate the precise reflectance based on Fresnel equations. These can be used to determine the exact coefficient of reflection based on the incident angle. In prior examples, a reflection coefficient of 10% was assumed. However, this value can be calculated. This information can be found on the on-line encyclopedia, Wikipedia, at http://en.wikipedia.org/wiki/Fresnel_equations.

The indices of reflection for the s-polarization and p-polarization are:

$$R_S = \left[\frac{n_1 \cos \theta_i - n_2 \sqrt{1 - \left(\frac{n_1}{n_2} \sin \theta_i\right)^2}}{n_1 \cos \theta_i + n_2 \sqrt{1 - \left(\frac{n_1}{n_2} \sin \theta_i\right)^2}} \right]^2$$

$$R_P = \left[\frac{n_1 \sqrt{1 - \left(\frac{n_1}{n_2} \sin \theta_i\right)^2} - n_2 \cos \theta_i}{n_1 \sqrt{1 - \left(\frac{n_1}{n_2} \sin \theta_i\right)^2} + n_2 \cos \theta_i} \right]^2$$

If, as in most cases, the incident light is of random polarization, the average reflection coefficient can be used.

$$R = \frac{(R_S + R_P)}{2}$$

To make matters worse, in our window example, there are actually two surfaces requiring consideration: the inner surface and the outer surface. Both surfaces actually cause reflection. Assuming that interference can be neglected, the combined reflection is:

$$R = 2 \times \frac{R}{(1 + R)}$$

In the case of a single-port design, the $n_2 > n_1$, and it can be shown that, at a minimum, the reflection coefficient at small incident angles is:

$$R = \left(\frac{(n_1 - n_2)}{(n_1 + n_2)} \right)^2$$

NOTES:

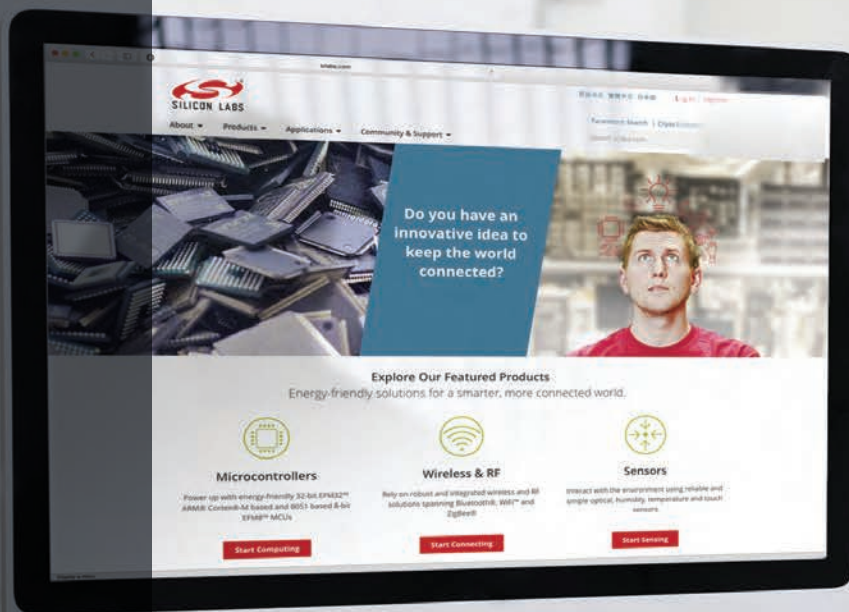

Smart.
Connected.
Energy-Friendly



Products
www.silabs.com/products



Quality
www.silabs.com/quality



Support and Community
community.silabs.com

Disclaimer

Silicon Laboratories intends to provide customers with the latest, accurate, and in-depth documentation of all peripherals and modules available for system and software implementers using or intending to use the Silicon Laboratories products. Characterization data, available modules and peripherals, memory sizes and memory addresses refer to each specific device, and "Typical" parameters provided can and do vary in different applications. Application examples described herein are for illustrative purposes only. Silicon Laboratories reserves the right to make changes without further notice and limitation to product information, specifications, and descriptions herein, and does not give warranties as to the accuracy or completeness of the included information. Silicon Laboratories shall have no liability for the consequences of use of the information supplied herein. This document does not imply or express copyright licenses granted hereunder to design or fabricate any integrated circuits. The products must not be used within any Life Support System without the specific written consent of Silicon Laboratories. A "Life Support System" is any product or system intended to support or sustain life and/or health, which, if it fails, can be reasonably expected to result in significant personal injury or death. Silicon Laboratories products are generally not intended for military applications. Silicon Laboratories products shall under no circumstances be used in weapons of mass destruction including (but not limited to) nuclear, biological or chemical weapons, or missiles capable of delivering such weapons.

Trademark Information

Silicon Laboratories Inc., Silicon Laboratories, Silicon Labs, SiLabs and the Silicon Labs logo, CMEMS®, EFM, EFM32, EFR, Energy Micro, Energy Micro logo and combinations thereof, "the world's most energy friendly microcontrollers", Ember®, EZLink®, EZMac®, EZRadio®, EZRadioPRO®, DSPLL®, ISOmodem®, Precision32®, ProSLIC®, SiPHY®, USBXpress® and others are trademarks or registered trademarks of Silicon Laboratories Inc. ARM, CORTEX, Cortex-M3 and THUMB are trademarks or registered trademarks of ARM Holdings. Keil is a registered trademark of ARM Limited. All other products or brand names mentioned herein are trademarks of their respective holders.



Silicon Laboratories Inc.
400 West Cesar Chavez
Austin, TX 78701
USA

<http://www.silabs.com>